



A. Uberti S.p.A.

Via Artigiani, 1 - Gardone V.T. (Brescia) - ITALY

Instruction Manual

BEFORE REMOVING THE FIREARM FROM THIS PACKAGE,
READ & UNDERSTAND THE PRECAUTIONS IN THE
INSTRUCTIONS MANUAL

SILVER BOY CAL.22LR

SPECIAL SAFETY INSTRUCTIONS

- 1) Uberti lever action rifles should never be carried with a cartridge in the chamber.
- 2) Carrying this style of rifle with a cartridge in the chamber can result in an accidental discharge if the firearm is accidentally dropped or if the hammer is struck.
- 3) The lever locking mechanism is designed to prevent an accidental discharge. However, no mechanical device is foolproof and, accordingly, these procedures must be followed.
- 4) Due to the fact that in a tubular magazine rifle the cartridges are stacked one behind the other, only factory ammunition should be used.
- 5) We recommend against using old ammunition in these rifles as primers, powder and brass cartridge cases can deteriorate and cause damage to the rifle or injury to the shooter or others.
- 6) Uberti assumes no liability for incidents occurring through the use of reloaded ammunitions.
Use **ONLY COMMERCIALY** loaded cartridges that have been loaded in accordance with SAAMI or C.I.P. standards.

HOW TO CHECK TO SEE IF YOUR GUN IS UNLOADED

Place your firearm in the Safety-On position using the procedure described in this manual.

With your finger away from the trigger and your gun pointed in a safe direction pull down on the lever to open the action. Visually inspect the chamber to see if there is a round in it or to see if there is a round on the carrier.

If you see nothing and want to load your gun: follow the directions under the heading "How to Load Your Firearm" below.

If there is a round visible and you want to unload your firearm follow the directions under the heading "How to Unload the Magazine and Chamber" below.

HOW TO PLACE YOUR HAMMER IN THE SAFETY-ON POSITION

When the hammer is fully forward (in the discharged or at-rest position):

Always point the gun in a safe direction. With the hammer in the fired position (hammer down) (See photo Fig.1), gently pull back the hammer about 1/4" until you hear the first click. With your thumb still on the hammer, gently release it forward. Your hammer should remain slightly above the fully-down position. If so your hammer is now in the safety position (See photo Fig.2). Gently pull the trigger. The hammer should not move.

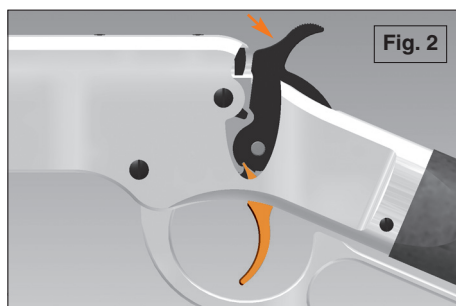
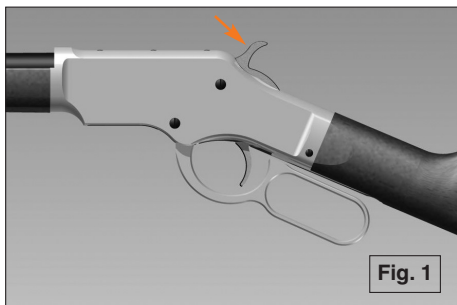

When the hammer is fully cocked (in the ready-to-fire position):

With the gun pointed in a safe direction and the hammer back in the fully cocked position (See photo Fig.3), hold the hammer tightly with your thumb. KEEP YOUR THUMB ON THE HAMMER AT ALL TIMES DURING THIS SEQUENCE. Pull back slightly on the hammer and then, with your index finger, apply light pressure on the trigger to release and gently lower the hammer. After the hammer starts to move forward, take your finger off the trigger and gently lower the hammer the rest of the way until it comes to rest in the safety position (See photo Fig.2). If you gently pull the trigger it should not move and the hammer should not fall.

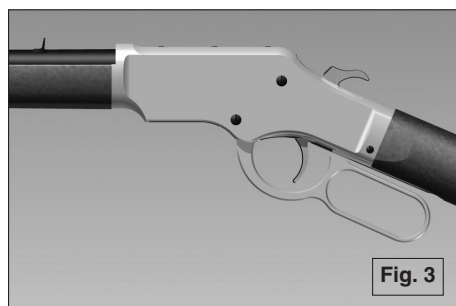

HOW TO UNLOAD THE MAGAZINE AND CHAMBER

Point the muzzle in a safe direction and ensure that the hammer is in the "Safety-On" position. Twist the inner magazine assembly counter-clockwise until the retaining stud aligns with the slot in the magazine tube (see photo Fig.5). Pull the assembly completely out of the magazine tube. Then point the gun downwards to allow the cartridges to fall out. Replace the inner magazine tube.

SILVER BOY CAL.22LR

N.	Code No.	Q.ty	Description	N.	Code No.	Q.ty	Description
001	2200001	1	FRAME	113	200113	1	MAGAZINE FOLLOWER
002	2200002	1	HAMMER	116	2200116	1	OUTER MAGAZINE TUBE
003	2200003	1	BARREL CAL.22LR -19"	118	2200118	1	INNER MAGAZINE TUBE
007	2200007	1	CARRIER BLOCK	119	400692	2	FRONT SIGHT SCREW
010	2200010	1	TRIGGER	122	2200122	1	BARREL BAND SCREW
015	202015	1	FRONT SIGHT	132	2200132	1	EJECTOR
018	2200018	1	CARRIER BLOCK SPRING	135	2200135	1	EJECTOR SPRING
019	2200019	1	TRIGGER SPRING	154	2200154	1	REAR SIGHT
020	2200020	1	MAINSRING	167	2200167	1	TRIGGER GUARD SCREW
022	2200022	1	CARRIER BLOCK PIN	170	2200170	1	LOCKING BRACE
026	2200026	1	TRIGGER GUARD	178	2200178	1	HAMMER PIN
052	2200052	1	CARRIER BLOCK SCREW	205	2200205	1	LEVER CAM
057	2200057	1	STOCK	245	2200245	1	SPACER
058	2200058	1	PLASTIC BUTT PAD	275	2200275	1	MAGAZINE TUBE BEARING
062	2200062	2	BUTT PAD SCREW	281	202281	1	MAGAZINE TUBE BEARING
063	200062	1	TRIGGER GUARD SCREW	330	2200330	1	STOCK, DRAW SCREW WASHER
068	2200068	1	FOREND	429	2200135	1	EXTRACTOR SPRING
079	2200079	1	EXTRACTOR	609	2200178	1	LOCKING BRACE PIN
081	2200081	1	BARREL BAND	709	2200709	1	LOCKING BRACE SPRING
089	2200089	1	LEVER	714	2200714	1	MAIN SPRING GUIDE
095	7000709	1	FIRING PIN SPRING	738	2200738	3	SCOPE PLUG SCREW
096	2200096	1	MAGAZINE TUBE SPRING	769	2200769	1	STOCK, DRAW SCREW
097	2200097	1	BREECH BLOCK CAL.22LR	770	2200770	1	CARRIER BLOCK PIN SPRING
098	2200098	1	FIRING PIN	774	2200108	1	EJECTOR PIN
099	2200099	1	TRIGGER PIN	797	2200797	1	MAGAZINE TUBE RING
101	2200101	2	LEVER SCREW	798	2200798	1	CARTRIDGE STOP SPRING
104	2200104	1	FIRING PIN STOP PIN	799	2200799	1	CARRIER BLOCK PIN SCREW
108	2200108	1	EXTRACTOR PIN	801	2200801	1	REAR CARRIER BLOCK SPRING
110	2200110	1	MAGAZINE TUBE PLUG PIN	805	2200805	1	CARTRIDGE STOP SCREW
114	2200114	1	MAGAZINE TUBE CAP				

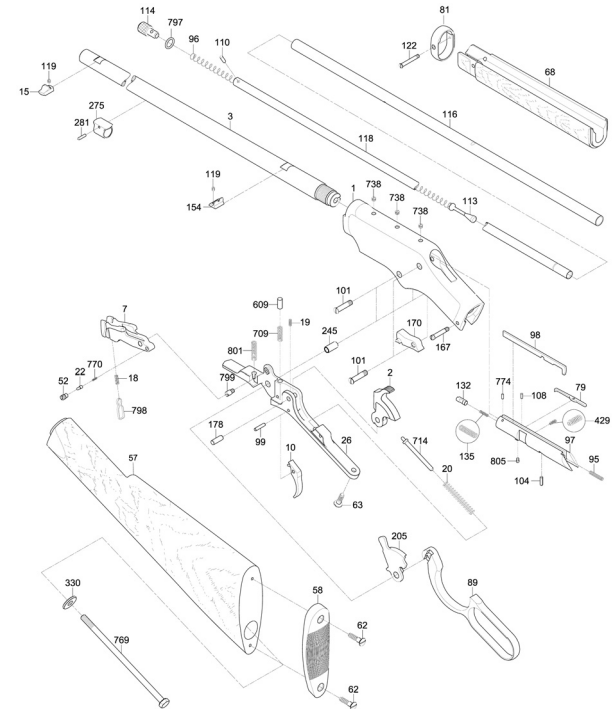

With the muzzle pointed in a safe direction and your finger away from the trigger, work the lever to expel the chambered round (if any). **Continue to cycle the lever until you are sure there are no more live cartridges in the action. Visually and physically verify that the chamber and magazine are empty.**

HOW TO LOAD YOUR FIREARM

Verify that the rifle is unloaded and pointed in a safe direction. Check that the ammunition is correct for the rifle (.22LR) – **Never use .22Short, .22Long or .22 Magnum cartridges in a firearm chambered for .22LR**

To load the magazine tube **place the hammer in the safety position** and make sure the lever is closed. Twist the inner magazine assembly counter-clockwise, until the retaining stud aligns with the slot in the magazine tube (See photo Fig.4). Pull the tube out until the follower clears the loading window inside the magazine tube. Point the barrel upwards and insert the cartridges (with the rim end down) into the loading window of the magazine tube. **Do not overload the rifle – Its' maximum capacity is 14 rounds.**

When the magazine is loaded push the inner tube down. Align the retaining stud with the slot in the magazine tube. Then twist the inner tube clockwise until the retaining stud seats in the locked position. Please pay attention when you push the inner tube because it is under spring tension and could fly out if you let go of the inner tube before the retaining stud is locked in position on the outer magazine tube. Your gun is now loaded.

HOW TO USE YOUR GUN

To chamber your round: With the magazine loaded lower the lever and pull it back completely up into the closed position: **Attention: The hammer will remain in the fully-cocked position. Your gun is now ready to fire when you pull the trigger.**

If you are not going to fire the rifle immediately we recommend unloading the gun or, if you want it to remain loaded, lower the hammer to the Safety-On position (see instructions above) and keep it there until ready to fire. When you are ready to fire, pull the hammer back into the fully cocked position and pull the trigger. The gun will fire.

To chamber the next round, completely lower the lever and pull it all the way back up again to the closed position. This operation will eject the spent cartridge and, at the same time, transfer the next round from the magazine tube into the chamber. **Attention: The hammer will remain in the fully cocked position, ready to fire.**

When you have finished firing make sure your gun is completely empty by cycling the action without touching the trigger four or five times until no further rounds eject. This should eject all cartridges but to make sure use the How to Check if Your Gun is Unloaded procedure previously described. Make sure your hammer is always in the Safety-On position (see photo Fig. 2). Make sure the magazine tube and chamber are completely empty.

